

SANDSUN

OPERATION MANUAL
使用說明書

QUICK DIE CHANGE SYSTEM

MODLE : PB08-1P3V-AC110V

SANDSUN PRECISION MACHINERY CO.,LTD
山田順精機股份有限公司

====CONTENTS====

I .OPERATION CHECKLIST (Please read the directions before using)

● AIR DRIVE HYDRAULIC PUMP UNIT -----	1-1
● ELECTRIC CONTROL OPERATION PANEL -----	1-2
● PRE-OPERATION CHECKLIST -----	1-3
● OPERATION CHECKLIST -----	1-4
● ELECTRIC CONTROL PANEL FUNCTION -----	1-5
● DIE CHANGE OPERATING SEQUENCE -----	1-6

II .MAINTENANCE AND TROUBLESHOOTING

● TROUBLESHOOTING INSTRUCTION -----	2-1
● TROUBLESHOOTING INSTRUCTION -----	2-2
● AIR DRIVE HYDRAULIC PUMP ASSEMBLY DIAGRAM (一) -----	3-1
● AIR DRIVE HYDRAULIC PUMP ASSEMBLY DIAGRAM (二) -----	3-2
● AIR DRIVE HYDRAULIC PUMP PARTLIST -----	3-3
● NON-LEAK VALVE ASSEMBLY DIAGRAM -----	3-4
● DIE CLAMP ASSEMBLY DIAGRAM -----	4-1
● DIE LIFTER ASSEMBLY DIAGRAM -----	4-2
● ELECTRIC CONTROL CIRCUIT DIAGRAM-----	5-1

AIR DRIVE HYDRAULIC PUMP UNIT (Model:PB08-1P3V-AC110V)

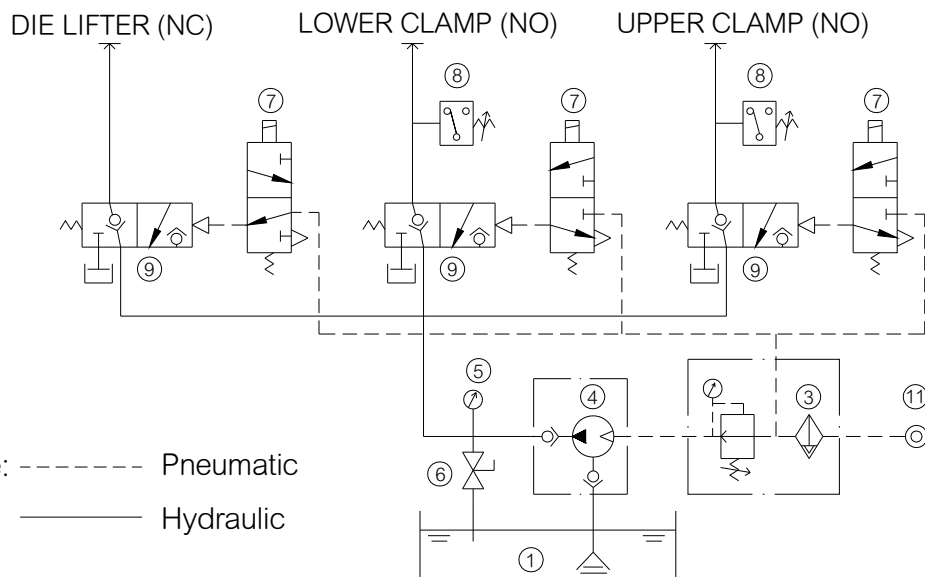
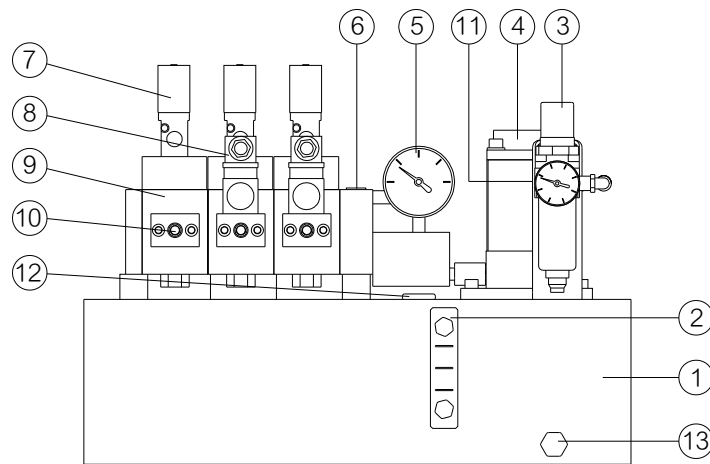

No	Part name	Specification	Qty	Remake
1	Oil tank	8 Liter	1	
2	Oil level gauge	LG-3 "	1	
3	Filter / Regulator	1/4 PT	1	Input pneumatic = 5 kgf/cm ²
4	Air drive hydraulic pump	PB-08	1	Output hydraulic = 250 kgf/cm ²
5	Hydraulic gauge	1/4PTx600 kgf/cm ²	1	
6	Air drain bolt	M10x1.5P	1	
7	Air solenoid valve	VO307-3D-Q-AC110V	3	
8	Hydraulic pressure switch	ST-P40	2	Set hydraulic = 200 kgf/cm ²
9	Non-leak valve	SV-04	3	
10	Hydraulic outlet base	1/4 PT	3	
11	Air inlet port	1/4 PT	1	
12	Oil supply port	3/4"-16UNF	1	
13	Oil drain bolt	W1/2"-12	1	

ELECTRIC CONTROL OPERATION PANEL



Pre-operation checklist : (Please read the directions before using)

- I \ Adding probably hydraulic oil in oil tank ①, can be used ISO-VG-32 or other similar hydraulic oil.
- II \ The air inlet ① pressure of the air regulator ③, should be higher than 5 kgf/cm².
- III \ When installation, the voltage of electric control panel and solenoid ⑦ should be the same.
- IV \ When installation, the hydraulic pipe or other parts should be cleaned exactly and the pipe should be always kept clean.
- V \ The method and sequence of air drain:
 - 1 \ Air drive hydraulic pump unit : (this procedure only used on the first time or changing oil)
 - (1) Please turn off all the switches on the panel before you turn on power,.
 - (2) Power switch → ON
 - (3) Air supply → Open.
 - (4) Loosen the air drain bolt ⑥ anti-clockwise around 1/2~1 cycle. (the bolt can't be pulled out)
 - (5) Adjusting air regulator ③ to keep the pressure on the pressure gauge to be 1.5 ~ 2 kgf/cm², at the same time, the pump will keep acting.
 - (6) Waiting about 20 seconds to let air exhaust from pump smoothly.
 - (7) Fasten the air drain bolt ⑥ clockwise to stop the pump and the pressure on the hydraulic gauge ⑤ will be up.
 - (8) If the pump still acting, the hydraulic gauge ⑤ don't go up. This means the air didn't exhaust fully out of the pump. Please repeat the step from (4) ~ (7), till the air totally exhaust from the pump.
 - 2 \ The pipes of upper and lower clamping : (to practice when finish assembling or change pipes)
 - (1) Loosen the end on the clamping hydraulic hose of the upper and lower clamp separately.
 - (2) Turn on the upper and lower clamp switch separately → ON. (The pump is starting acting at this time.)
 - (3) Check if there has any oil draining out of the connector and the oil doesn't include air bubble, then fastening the connection.
 - (4) When the hydraulic hose was fastened, pay attention on the hose to let it keep out of unusual totality.
 - (5) Pump will be keep action until the clamps were clamping completion, then pump will be stop action.
 - (6) Adjusting the air pressure of the air regulator ③. The finger guide of the hydraulic gauge ⑤ will keep up. The pressure value should be at the normal working pressure (about 230 ~ 250 kgf/cm²), to keep the machine operating normally.

Operation Checklist :

- I \ *QDC system is forbidden running machine when clamping in only single die (clamp Upper or Lower Die only). To ensure the safety working status, we strongly request user keep machine running under Upper and Lower Dies are both clamped.*
- II \ When the machine works normally the air supply should not be turned off.
- III \ The air supply of the air driven hydraulic pump unit should be keep dry (to install air dryer will make the air in better condition), to prevent the life of pump & connected components be shorten by fur.
- IV \ Regularly check the oil tank ① to see if there still is enough oil in it. (The oil level gauge ② shouldn't be lower than " L ")
- V \ If the oil tank be added oil often, there may oil is leaked out in pipe or components. Please check all the pipes and section connected.
- VI \ The oil in the oil tank ① should be changed every two years or when the oil quality gets worse.
- VII \ When the specification of clamp is not match the die, operate the following steps : The QDC system will be off-line with machine.
 - 1. Power switch → ON
 - 2. Interlock switch → ON
 - 3. Die change switch → ON
 - 4. Clamp switch → OFF (including upper and lower clamp switch)
 - 5. Interlock switch → OFFAs above steps are finished, please fix the Dies by bolt or other way, the machine will be operated in off-line mold.
- VIII \ Although Dies are fixed by other methods, all clamps will be clamping automatically themselves when the machine is power off, the same function as keep clamping to prevent Dies fall down when power failure occurs. In the next time as user switch on the machine, turn QDC system in off-line according to the 5 steps indicated VII.
- IX \ *In rare occasion if user has to produce without using all necessary clamps, please fix die with proper screws to secure working on safety. If the clamping capacity is not enough may cause dies in damage or be taken off from machine.*
We, Sandsun Precision Machinery Company, will not take the responsibility if user doesn't operate according to the instructions.

Electric control panel functions:

I \ Interlock switch:

1. "ON" —
 - (1). can operate the upper and lower clamps to clamping or unclamping.
 - (2). must to use quick die change system, then the press can be operated.
2. "OFF"—
 - (1). can' t operate the upper and lower clamps to clamping or unclamping.
 - (2). no using quick die change system, then the press can be operated.

II \ Die change switch:

1. " ON " — can operate the upper and lower clamps to unclamping.
2. " OFF " — can' t operate the upper and lower clamps to unclamping.

III \ Clamp switch: (including upper and lower clamp)

1. "ON" — clamping
2. "OFF"— unclamping

IV \ Clamp indicator lamp: (including upper and lower clamp)

When the die was clamping completion by the clamp of the upper or lower clamp and the oil pressure is higher than the setting pressure (200 kgf/cm²), the green indicator lamp - light.

V \ Die lifter switch:

1. "ON" — up the die
2. "OFF"— down the die

VI \ Clamp off indicator lamp:

1. Lamp on: (if the interlock switch "ON", could be the following abnormal conditions)
 - (1). If not all clamps of the upper and lower clamp don' t clamping completion.
 - (2). All clamps are clamping completion, but the hydraulic pressure is lower than 200 kgf/cm².
 - (3).Outer pipe or some oil leakage, cause the hydraulic pressure is lower than 200 kgf/cm².
 - (4).Air supply pressure is too low, to make the hydraulic pressure is lower than 200 kgf/cm².
2. Lamp off:
 - (1). When the interlock switch "ON", upper and lower clamp in clamping completely, and upper and lower clamp green indicator light is lamp on.
 - (2). When the interlock switch "OFF".

Die change operating sequence:

I \ Take out the die :

- 1 \ Operate the machine → close the die.
- 2 \ Interlock switch → "ON".
- 3 \ Die change switch → "ON"
- 4 \ Clamp switch → "OFF" (including upper and lower clamp)
- 5 \ Take out the clamp → put in clamp hanger.
- 6 \ Interlock switch → "OFF".
- 7 \ Operate the machine → up the slide to top position.
- 8 \ Die lifter switch → "ON" (if there is no installation ,save this operation)
- 9 \ Take out the die.

II \ Setting in the die :

- 1 \ Interlock switch → "OFF"
- 2 \ Die lifter switch → "ON" (if there is no installation ,save this operation)
- 3 \ Moving in the die.
- 4 \ Die lifter switch → "OFF" (if there is no installation ,save this operation)
- 5 \ Setting the die in proper position.
- 6 \ Moving in the clamps to proper position.
- 7 \ Interlock switch → "ON"
- 8 \ Clamp switch → "ON" (including upper and lower clamp)
- 9 \ Die change switch → "ON"
- 10 \ Try operating the machine.

III \ If there is die arm installed, then the die moving in and moving out can be done with the help of die arm.

Troubleshooting instruction (Refer to Page: 3-1. 3-2. 3-3. 3-4 assembly diagram)

Item	Trouble	Cause	Step for Solution
1.	Pump can't acting	1. Air supply valve has been closed.	Open the air supply valve.
		2. Pump caught by fur.	Disassemble and clean the exchange valve ⑳ and piston ⑭ ,then smear the grease.
		3. Spring ⑪ broke.	Change the spring.
		4. Spool ㉟ caught.	Disassemble and check if any damage happens from the oil seal ⑨ and spool ㉟
		5. Air pressure is too low or not enough.	Adjust the air pressure to over 3 kgf/cm ² .
2.	Air leak from the pump	1. Exchange valve ㉒ caught by fur.	Disassemble and clean cover ㉓ 、exhaust base ㉔ 、exchange valve ㉒ 、cylinder body ㉑, then smear the grease.
		2. The o-ring of the exchange valve ㉒ was damaged.	Change the O-ring ㉙ 、㉚ ◦
		3. There is not enough oil in the oil tank.	1. Refill hydraulic oil . 2. Let air drain out, follow steps: a. Adjust air pressure to 1.5 ~ 2 kgf/cm ² . b. Loosen the air drain bolt in anti-clockwise around 1/2 ~ 1 circle. c. Waiting about 20 seconds to let air drain out. d. Fasten the air drain bolt in clockwise. e. Pump will stop acting and the pressure will go up on the hydraulic gauge. f. Adjust the air pressure to the system needed.
3.	Pump can't stop - inability to build-up hydraulic pressure when clamping 、 unclamping and die lifter go up and down.	1. There is not enough oil in the oil tank.	
		2. Oil leak out from silencer ㉞	Check if any damage happens from the inlet base ① and oil seal ⑨.
		3. Air drain bolt ⑥ loosen.	Fasten the air drain bolt.
		4. Inlet base ① or inlet valve ② damaged or caught.	Check if any damage happens from the inlet base and inlet valve.
4.	Pump can't stop - can clamping and die lifter go up, but when be unclamping and die lifter go down the pump can't stop. (the hydraulic gauge will repeatedly go up and down)	1. The check valve ⑫ was damaged on the non-leak valve.	1. Check the trouble is which circuit on non-leak valve. 2. Close the air supply valve. 3. Separate the bolts by connect and fix the non-leak valve. And take out the non-leak valve which cause trouble. 4. Take out the inlet base ⑬ on the non-leak valve. Check whether the tight-fit get damaged of between the inlet base and check valve ⑫. 5. Check whether has any residue inside the non-leak valve and clean it. 6. Reassembly all the components sequence (attention the connection facing on the O-ring BP-7 and P-4. to see if there has good assembly)

Item	Trouble	Trouble cause	Troubleshooting steps
5.	Pump can't stop - can unclamping and die lifter go down but when be clamping and die lifter go up the pump can't stop. (the hydraulic gauge will repeatedly go up and down)	1. Oil leakage on the pipe	Check which has oil leakage and fasten.
		2. The check valve ⑨ was damaged on the non-leak valve.	1. Check the problem is which circuit on non-leak valve. 2. Close the air supply valve. 3. Take out upper cover① on the top of the non-leak valve. And take out the bush ⑦ check whether the tight-fit get damaged of between the bush and check valve⑨. 4. Check whether has any residue inside the non-leak valve and upper cover. And clean it. 5. Reassembly all the components sequence.
6.	System shut down immediately	1. Stop the control power. (power lamp will turn off)	1. Check whether has burn down on the fuse. 2. Check whether has bad connection in the line. 3. Check whether has component loosen or inside joint carbon on the relay.
		2. Operating is mistake.	Refer to the electric control box function directions.
7.	Can't unclamping	1. Air supply valve has been closed	Open air supply valve.
		2. Operating is mistake.	Refer to the electric control box function directions.
		3. Fuse was burn down.	1. Check whether was turn off in the power lamp. 2. Take out the loading side (solenoid valve, lamp, relay). Use meter to measure the loading resistance. 3. Measure the line resistance. 4. Change the fuse (3A) after to removes the trouble.
		4. Bad connection in the line	1. Check whether has any damage on the outer electric line. 2. Check whether has any loosen inside electric line. 3. Check the switch can turn off regular.
		5. Operating is mistake to operation panel.	Refer to the page 1-6.

AIR DRIVE HYDRAULIC PUMP (Model:PB) ASSEMBLY DIAGRAM

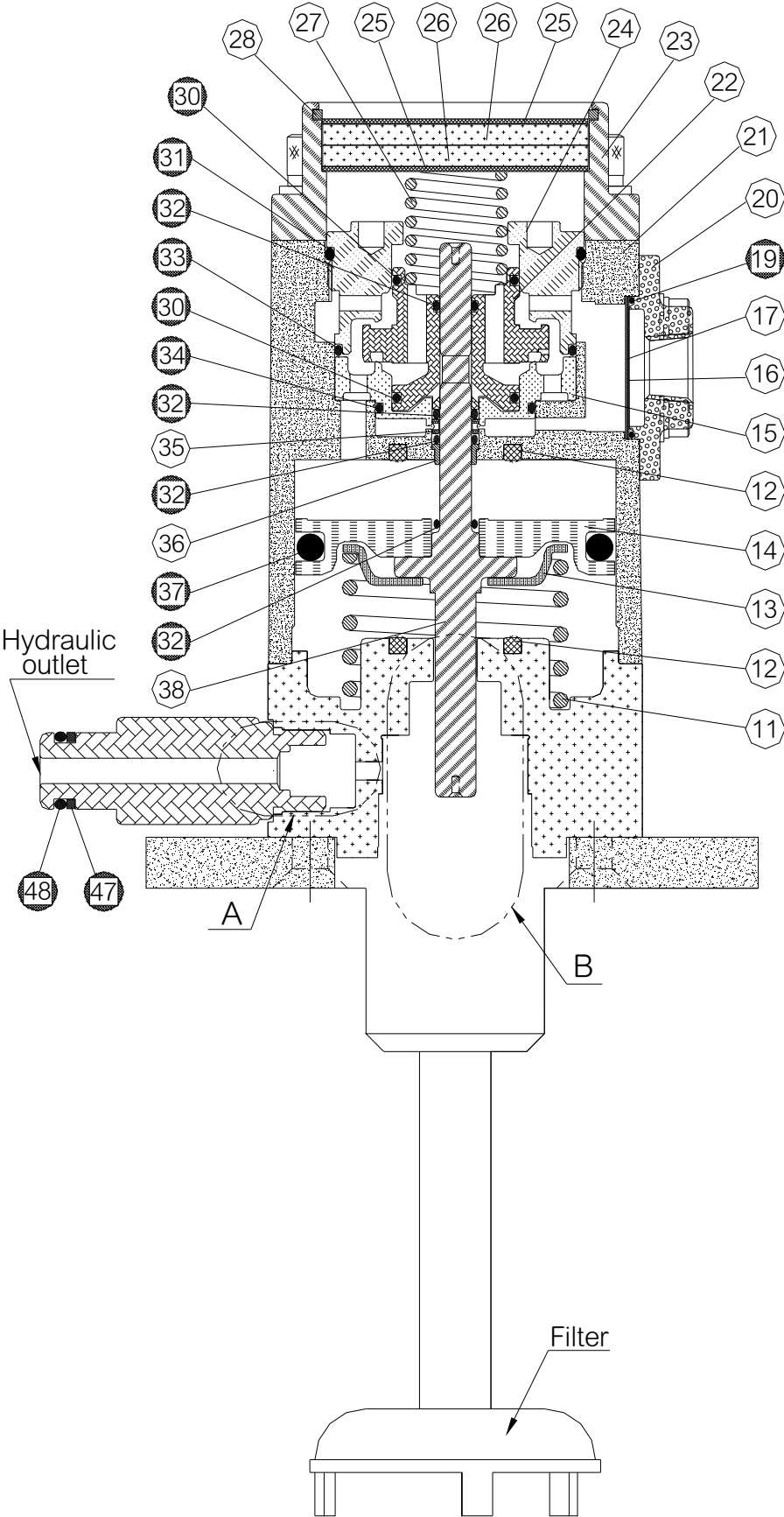

AIR DRIVE HYDRAULIC PUMP (Model:PB) ASSEMBLY DIAGRAM

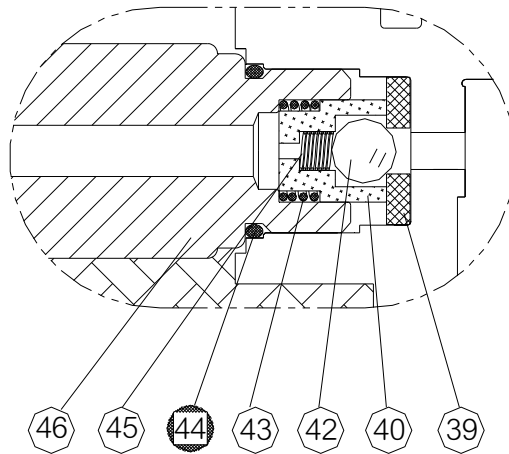

A

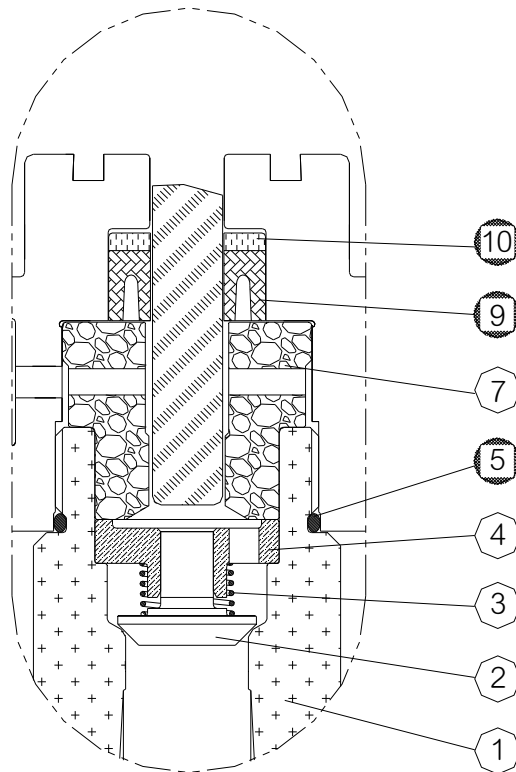

B

AIR DRIVE HYDRAULIC PUMP (Model:PB08) PART LIST

No	Part name	Specification	Qty	No	Part name	Specification	Qty
1	Inlet base	01-5102	1	27	Spring	62-2600	1
2	Inlet valve	62-5300	1	28	Check ring	R-52	1
3	Spring	62-5400	1	30	O-ring	ARP-568-020	2
4	Inlet valve base	62-5500	1	31	O-ring	ARP-568-032	1
5	O-ring	ARP-568-023	1	32	O-ring	ARP-568-010	4
7	Spool bush	62-5608	1	33	O-ring	ARP-568-031	1
8	Hydraulic body	01-5008	1	34	O-ring	ARP-568-024	1
9	Oil seal	UN-8	1	35	Bush-(2)	61-2200	1
10	Back-up ring	TF-8-18-2	1	36	Bush-(1)	61-2100	1
11	Spring	62-4400	1	37	O-ring	AP-53	1
12	Buffer pad	61-5700	2	38	Spool	62-4208	1
13	Spring base	62-4300	1	39	Check pad	61-6200	1
14	Piston	62-4100	1	40	Spring base	01-2300	1
15	Pilot base	62-2300	1	42	Steel ball	∅ 6.3mm	1
16	Filter	61-3200	1	43	Spring	01-2400	1
17	Filter plate	61-3300	1	44	O-ring	ARP-568-015	1
19	O-ring	ARP-568-022	1	45	Spring	01-2500	1
20	Air Supply base	61-3100	1	46	Outlet base	01-5201	1
21	Cylinder body	62-2001	1	47	Back-up ring	TP-11	1
22	Exchange valve	62-2400	1	48	O-ring	BP-11	1
23	Cover	62-2500	1				
24	Exhaust base	62-2900	1				
25	Silencer plate	62-2700	2				
26	Silencer	62-2800	2				

NON-LEAK VALVE (Model : SV-04) ASSEMBLY DIAGRAM

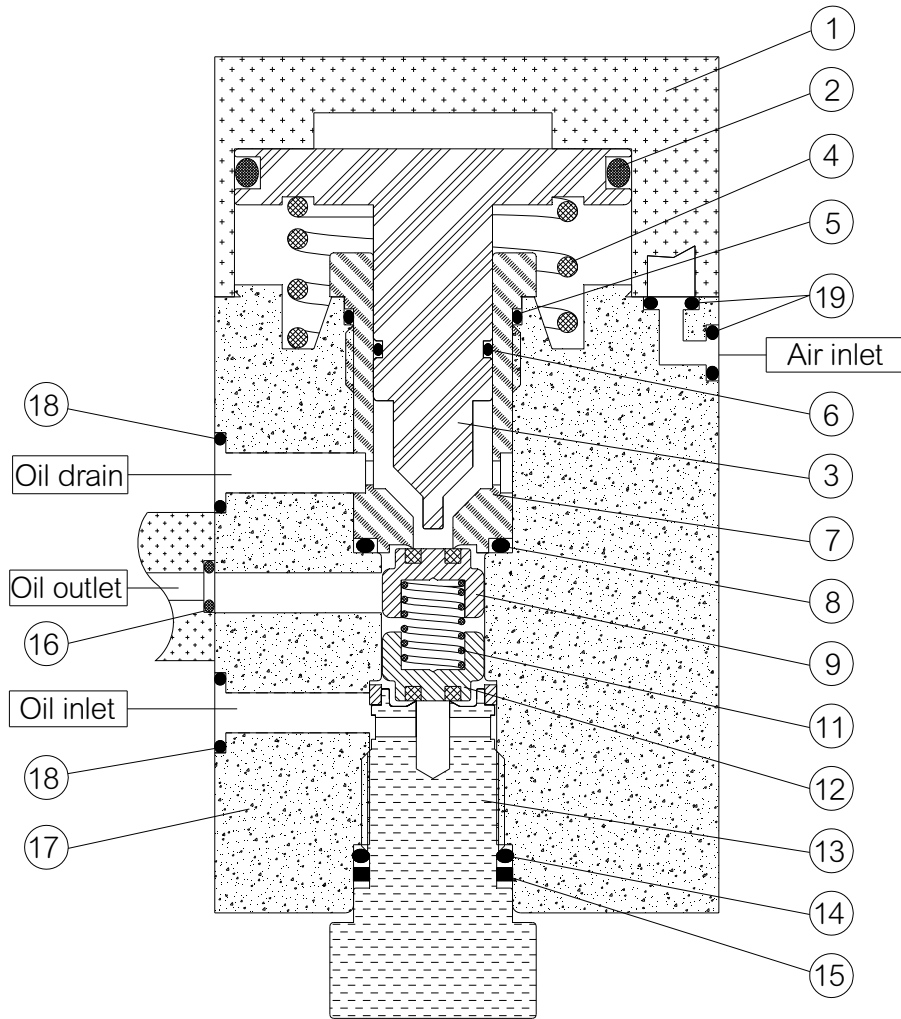

No	Part name	Specification	No	Part name	Specification
1	Upper cover	13-0201	11	Spring	13-4300
2	O-ring	AP-44	12	Check valve	13-4200
3	Piston	13-0300	13	Oil inlet base	13-4100
4	Spring	13-0500	14	O-ring	BP-16
5	O-ring	SM-20	15	Back-up ring	TP-16
6	O-ring	SM-12	16	O-ring	BP-12
7	Bush	13-4000	17	Valve body	13-0101
8	O-ring	BP-16	18	O-ring	BP-7
9	Check valve	13-4200	19	O-ring	P-4

DIE CLAMP (Model:CA) ASSEMBLY DIAGRAM

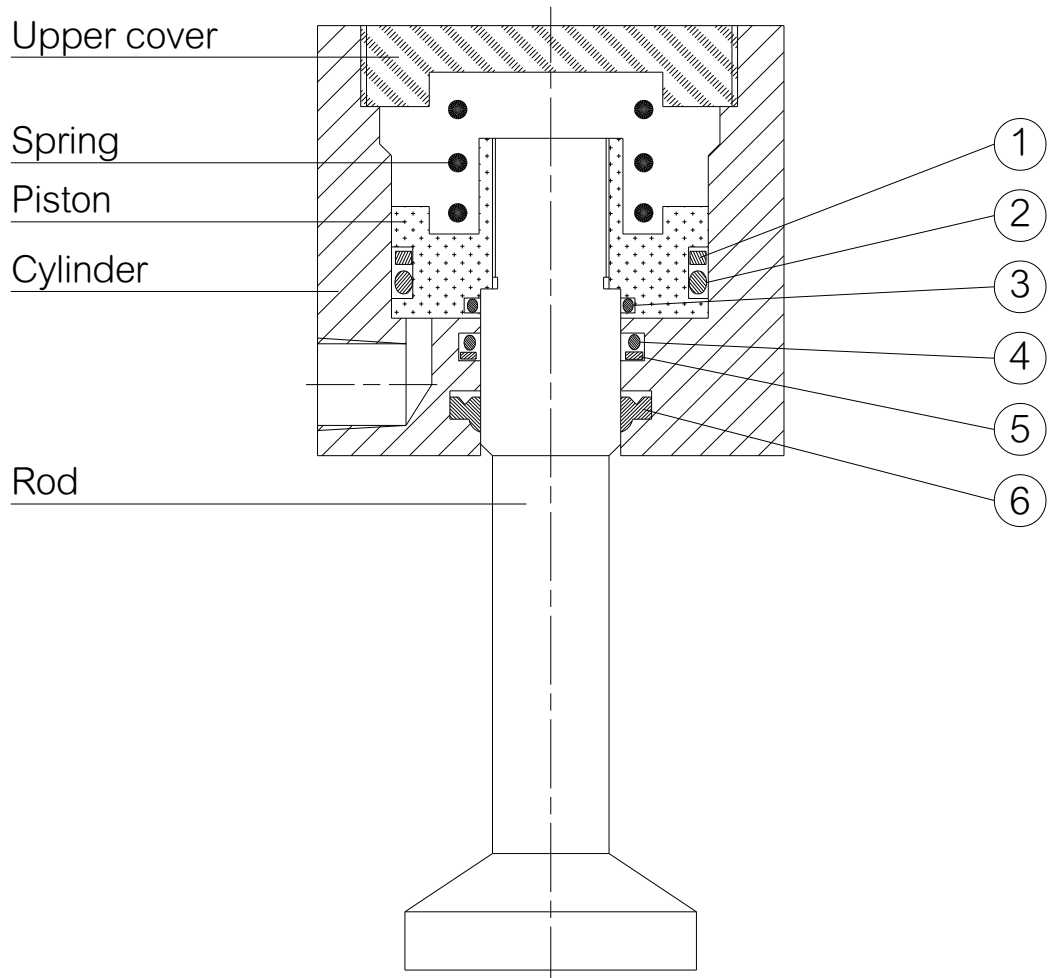

Selection	Model	①	②	③	④	⑤	⑥
		Back-up ring	O-ring	O-ring	O-ring	Back-up ring	Dust-proof ring
	CA-2	TP-31	AP-31	BP-18	AP-18	TP-18	DH-18
	CA-4	TP-44	AP-44	BP-25	AP-25	TP-25	DH-25
	CA-6	TP-53	AP-53	BP-32	AP-32	TP-32	DH-31.5
	CA-10	TP-70	AP-70	BP-40	AP-40	TP-40	DH-40
	CA-16	TP-95	AP-95	BP-50	AP-50	TP-50	DH-50
	CA-25	TP-120	AP-120	BG-60	AP-60	TP-60	DH-60
	CA-						

DIE CLAMP (Model:CB) ASSEMBLY DIAGRAM

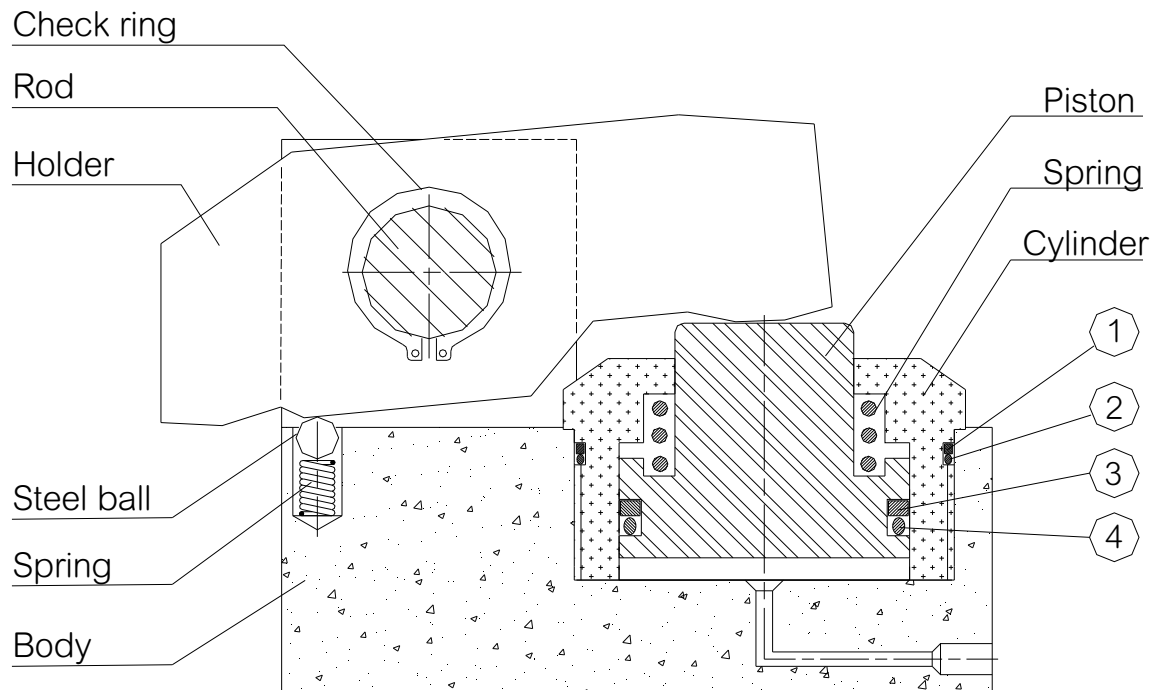

Selection	Model	① Back-up ring	② O-ring	③ Back-up ring	④ O-ring
	CB-2	TG-40	BG-40	TP-24	AP-24
	CB-4	TG-50	BG-50	TP-34	AP-34
	CB-6	TG-60	BG-60	TP-44	AP-44
	CB-10	TG-80	BG-80	TP-55	AP-55
	CB-16	TG-100	BG-100	TP-65	AP-65
	CB-25	TG-120	BG-120	TP-85	AP-85
	CB-				

DIE LIFTER ASSEMBLY DIAGRAM

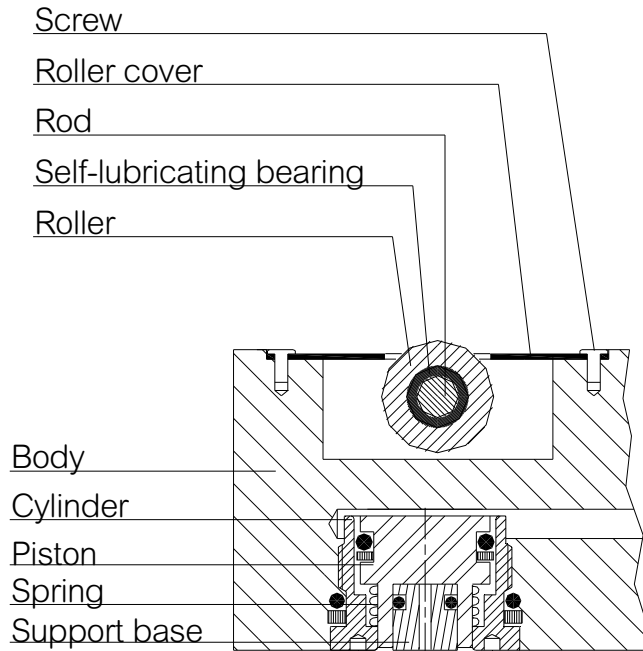

DL type

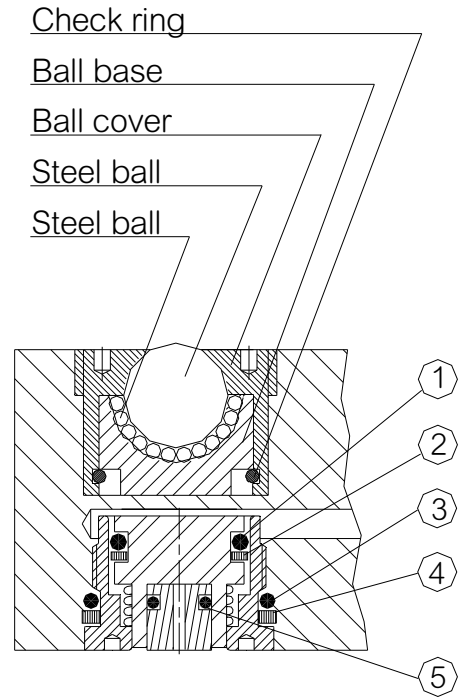

DB type

Selection	Model	① O-ring	② Back-up ring	③ O-ring	④ Back-up ring	⑤ O-ring
	DL-28	AP-14	TP-14	BP-20	TP-20	SM-6
	DB-28					
	DL-50	AP-20	TP-20	BP-32	TP-32	P-8
	DB-50					

ELECTRIC CONTROL CIRCUIT DIAGRAM

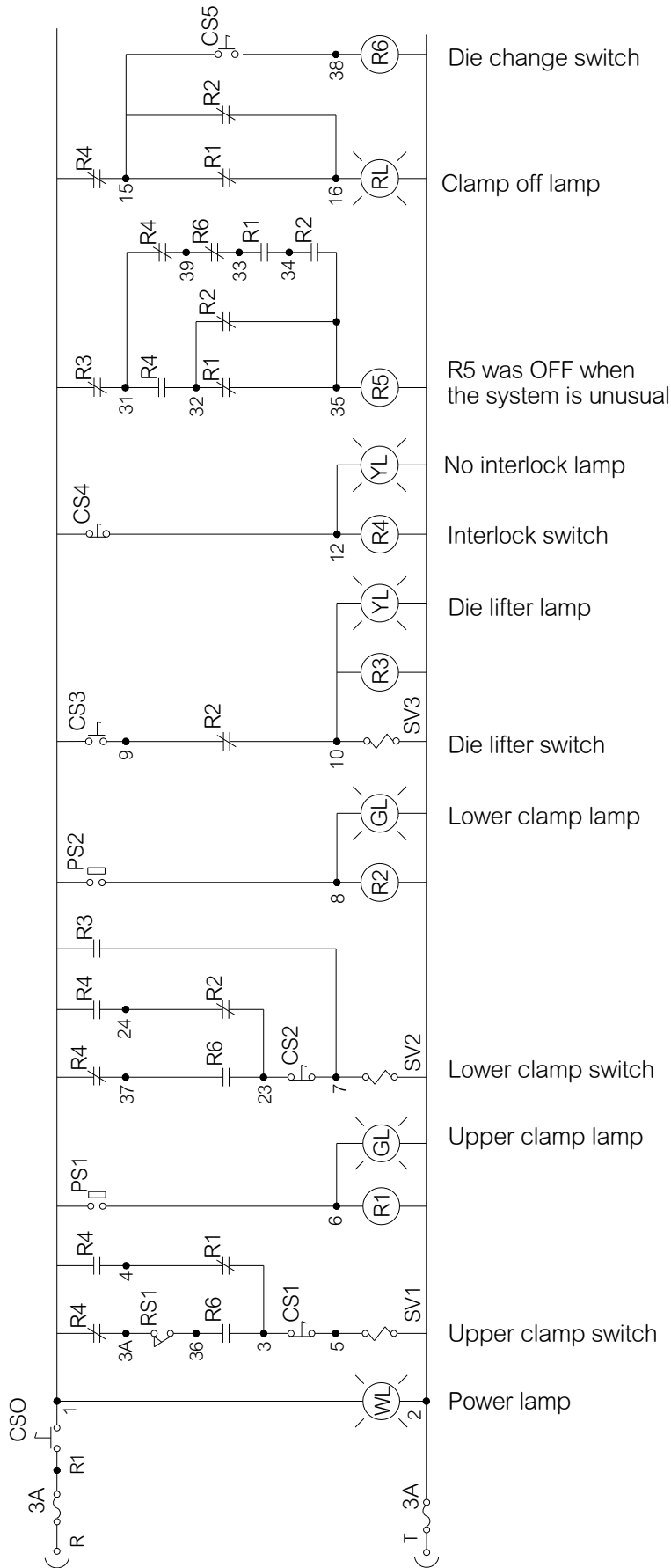

Exh part	Wiring no	Note
Air drive hydraulic pump	SV1 2	Upper clamp solenoid
	PS1 1	Upper clamp pressure switch
	SV2 2	Lower clamp solenoid
Press	PS2 1	Lower clamp pressure switch
	SV3 2	Die lifter solenoid
	RS1 3A	On the "bottom dead point", set the cam switch of unclamping the upper clamp.
E.S. 17	19	Interlock circuit to machine

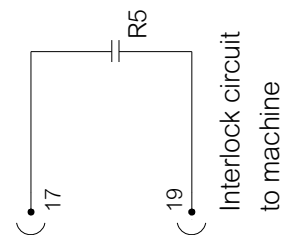



山田順精機股份有限公司
SANDSUN PRECISION MACHINERY CO.,LTD.
台灣省彰化縣大村鄉中山路三段 57 巷 7 號
NO.7, LANE 57, SEC.3, CHUNG-SHAN RD.,
DAH-TSUEN, CHANG-HWA, TAIWAN, R.O.C.
[Http://www.sandsun.com.tw](http://www.sandsun.com.tw)
E-mail : sandsun@ms26.hinet.net
TEL : 886-4-8536688 FAX : 886-4-8536699

山田順精密機械(蘇州)有限公司
SANDSUN PRECISION MACHINERY (SUZHOU) CO.,LTD.
江蘇省蘇州市吳中區甪直鎮映勝路
[Http://www.sandsun.com.tw](http://www.sandsun.com.tw)
TEL : 86-512-66026635 FAX : 86-512-66026637
東莞服務處：
東莞市虎門鎮東風管理區東北村新區
TEL : 86-769-85569867 FAX : 86-769-85569867